

the P.R. Skate, LLC

Pallet Rack Moving System

Product Manual



"Moving pallet rack in the 21st Century."

the P.R. Skate, LLC

Product Manual

In this manual we will cover both normal operation of the P.R. Skate moving system and safety issues that need to be addressed prior, during and after the use of the P.R. Skate moving system. This entire manual should be read and familiarized by every participant in the remodel and/or relocation of existing pallet rack. All safety guidelines of the P.R. Skate, LLC and your own company guidelines should be followed prior, during, and after use of the P.R. Skate moving system.

In using the P.R. Skate moving system, all standard safety equipment should be worn or used just as they would normally be used. Since the environment that the system would be used in is a construction environment, hard hats, gloves, eye protection, ear protection, work boots (steel toe), and proper work attire should be worn and/or used in conjunction with the P.R. Skate moving system.

The P.R. Skate moving system is just like any other tool you would use in completing a task, they all have safety guidelines that should be adhered to. While we maintain that the P.R. Skate system is a safe and effective tool when all safety standards and guidelines are adhered to, accidents can happen. Most accidents happen in unsafe work conditions or because of unsafe work practices. Safety guidelines and procedures are in place to help minimize work place accidents and should be adhered to.





The P.R. Skate moving system may not be appropriate for every type of pallet rack relocation project. If there are any doubts about the safety of crew and/or bi-stander in a particular project, the P.R. Skate LLC should be contacted prior to use and/or use of system (the P.R. Skate moving system) for the particular project should not be considered and/or used.

The goal of the P.R. Skate, LLC is to develop and test new ways of relocating rack and equipment in an efficient and safe manner. The safety of the operators of our equipment and general public is our number one goal when looking at new ways of moving today's equipment. The following safety standards should be implemented in all projects that the P.R. Skate moving system is used. The standards are for everyone's safety and well-being.

Product Manual

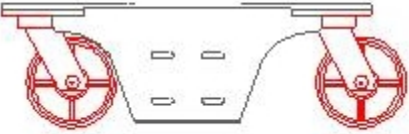
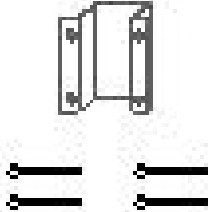
the P.R. Skate

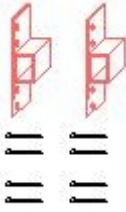
moving system component list

<p style="text-align: center;">the PR Skate</p>  <p style="text-align: center;">Qty. varies</p>	<p style="text-align: center;">Skate Clamp & bolts</p>  <p style="text-align: center;">Qty: Clamp – same as skate Bolts – 4 per clamp</p>
<p style="text-align: center;">Lifting Bar</p>  <p style="text-align: center;">Qty: 1</p>	<p style="text-align: center;">Lifting Bracket</p>  <p style="text-align: center;">Qty: 1</p>
<p style="text-align: center;">Upright or Frame Brackets</p>  <p style="text-align: center;">Qty: Brackets – 2 Bolts – 4 per bracket</p>	<p style="text-align: center;">Lifting Jack</p>  <p style="text-align: center;">Qty: 1</p>

This page was intentionally left blank.

Contents

- 1. Pre-system safety inspections**
 - 1.1. Rack inspection
 - 1.1.1. Frames
 - 1.1.2. Beams
 - 1.1.3. Electrical service
 - 1.1.4. Plumbing service
 - 1.2. Stored material inspection
 - 1.3. Relocation path inspection
 - 1.3.1. Floors
 - 1.3.2. Overhead
 - 1.3.3. Corners
 - 1.4. Equipment inspection
- 2. System set up**
 - 2.1. Staging equipment
 - 2.1.1. Skates
 - 2.1.2. Lifting system
 - 2.2. Attaching lifting system
 - 2.2.1. Lifting system
 - 2.2.1.1. Sliding lifting bracket
 - 2.2.2. Anchors
 - 2.2.3. Support Beams
- 3. System in action**
 - 3.1. Lifting rack
 - 3.2. Attaching skates
 - 3.3. Lowering rack onto skates
 - 3.4. Moving rack to new location
 - 3.5. Lifting rack for skate removal
 - 3.6. Skate removal
 - 3.7. Lowering rack into place
- 4. Post-system & Clean up**
 - 4.1. Rack anchoring
 - 4.2. Clean up
 - 4.3. Safety inspections
 - 4.4. Packing the system for storage

1. Pre-system safety inspections

1.1. Rack inspection – *Before system use, all inspections should be made.*

1.1.1. Frames – All the frames or uprights of the pallet rack run (continuous bays of racking) to be moved need to be inspected for prior damage and defects. Both the front, back and bracing should be inspected. If any structural damage exists, the PR Skate system should not be used on the damaged frame or upright. Examples of different types of damage are given below, but damage to pallet rack frames or uprights are not limited to the illustrations below.

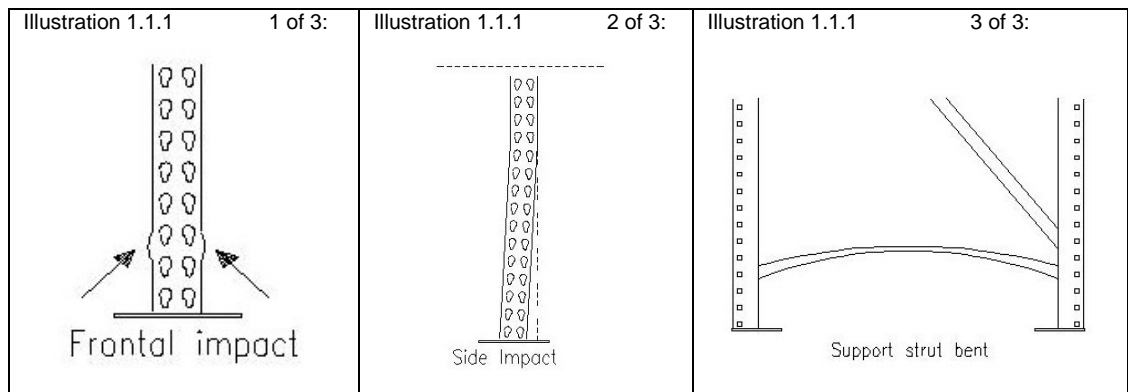

If an upright or frame is damaged the rack must be broken apart and frame removed before use of the PR Skate moving system.

1.1.2. Beams – All beams of the pallet rack run (continuous bays of racking) to be moved need to be inspected prior to the use of the PR Skate moving system.

A visual inspection of the beam level should determine if the beam level is overloaded with standing weight. **If a beam level appears to be over weight, then some of the stored material should be removed to reduce the weight on the beam level.** If there are any doubts if a beam level is overloaded, then some of the stored material should be removed to reduce the weight on the beam level. An overloaded beam level will have slight smile to it (see illustration below).

1.1.2. Beams – Continued...

You should be familiar with the weight capacities of the beams.

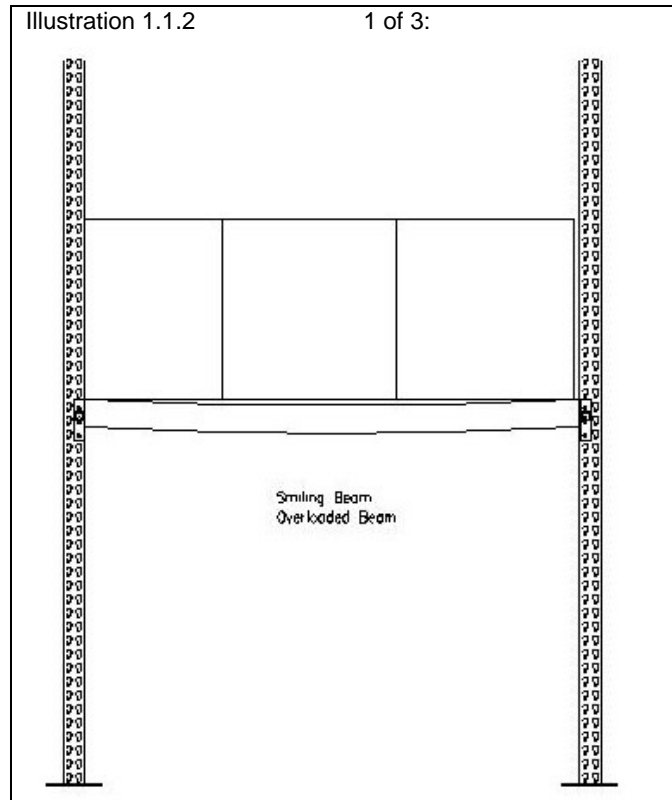

All beams should be visually inspected for safety pins and/or bolts. The rack manufacturers typically have pre-installed safety pins already installed on the beams they sell. **If the safety pins are no longer installed, a new safety pin and/or bolt must be installed to prevent the beam from lifting out of the frame sockets becoming dislodged from the frame or upright.** See illustrations below.

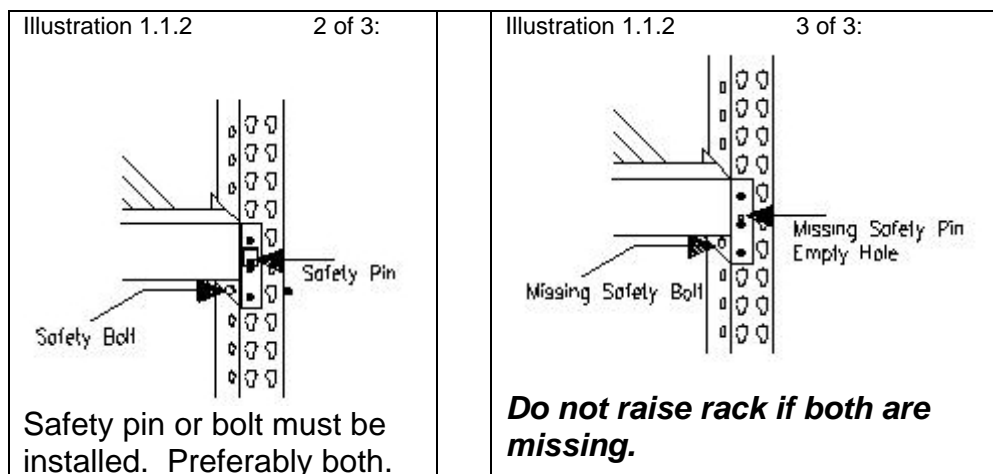

All beams must have safety pins and/or bolts installed prior to moving the rack with the PR Skate moving system.

1.1.3. Electrical service – The pallet rack run (continuous bays of racking) to be moved should be carefully inspected for any electrical services (outlets, lighting, hardwired machinery, data, phone, etc...) installed within the racking. If any such electrical services are found in the rack, the rack should not be moved in any way until qualified personnel disconnect the services.

1.1.4. Plumbing services – Prior to using the PR Skate moving system on a run (continuous bays of racking) of pallet rack, all plumbing services (fire protection sprinklers, water pipes, etc...) should be removed from the racking. Qualified personnel should do any such removal.

1.2. Stored material inspection – Stock material and/or product must be inspected prior to the use of the PR Skate moving system. The stocked material and/or product must be inspected for stability. Loose unstable product or stocked materials must be removed before the pallet rack is detached from the floor. If you encounter any potentially dangerous products or stocked material (sharp objects, hazardous, potential fire hazard, etc...), the product or stocked material should be removed from the rack prior to detaching the rack from the floor. Upon your inspection of the stored material or product, if you have any doubt in the safety of the stored material or product, that stored material or product should be removed prior to detaching the rack from the floor.

All products on the top beam level must be taken down for safety. This will reduce the risk of the rack being too top heavy. You want the weight towards the bottom of the rack and not all at the top.

To the right are some illustrations of unsafe product or stored material. The illustrations give some examples

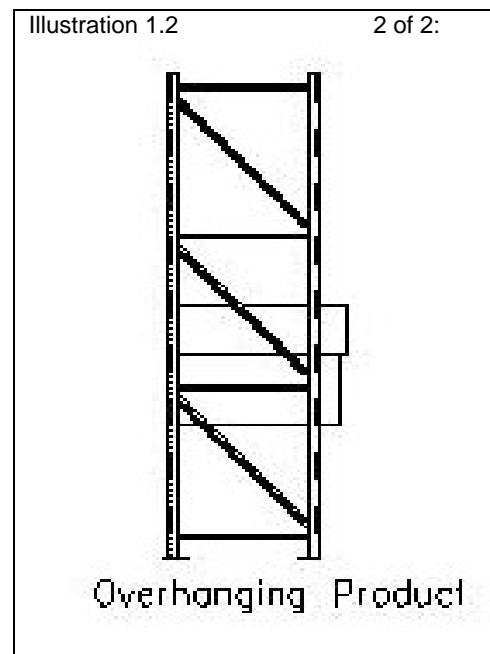
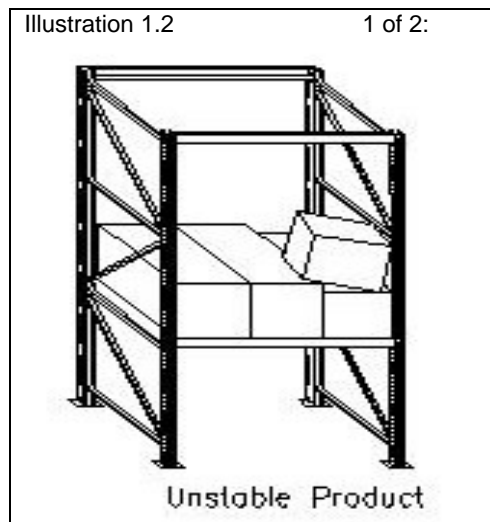

but safety of the product or stored materials stability is not limited to the examples below and is solely the judgment of the person doing the inspection.

1.3. Relocation path inspection – Before use of the PR Skate moving system all inspections must be made.

1.3.1. Floors – You will move the rack from point “A” to point “B”. The path you take in moving the rack must be inspected for safety. The floor path should be broom swept to clear all debris. When inspecting the floor path, look for irregularities in the floor panels. The maximum irregularities in floor panel height for the skates to roll over is 7/16”. If the irregularities are greater than 7/16”, the skate will high center on the irregularity. See *illustration below*. Besides the height irregularity also look for unusually large cracks or divots in the concrete floor. Any cracks or divots wider than 3/4” must be avoided. See *illustrations below*.

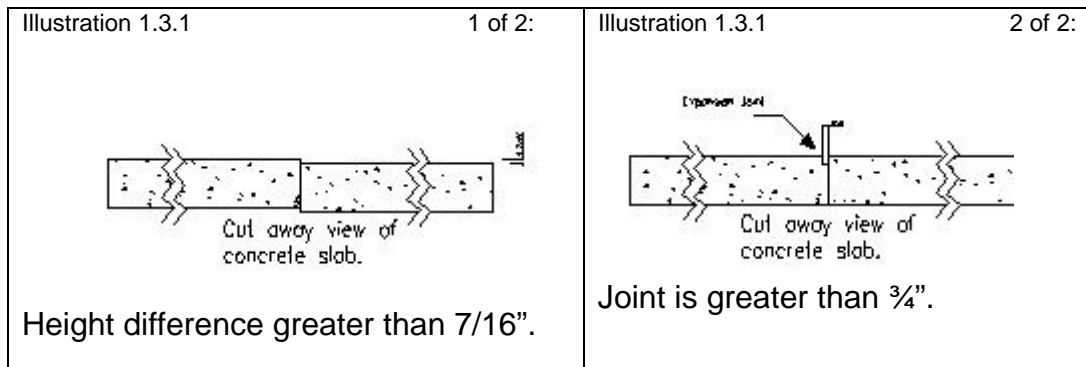

1.3.2. Overhead – Once the floor path is determined for moving the rack from point “A” to point “B”, inspect the overhead path. To inspect the overhead path, one must know the height of the rack. Look for low lighting, fire protection systems (sprinklers), HVAC units and ducting, roof trusses, signs, etc... Along with a clear floor path, the overhead must not have any obstacles as well.

1.3.3. Corners – Typically you will have to maneuver the racking around a corner. One will have to estimate how many bays one can move around the corner without damaging or jamming the racking with other fixtures or equipment. Once you have determined how many bays will move around the corner, you must break the rack into that many sections before the rack is detached from the floor. See *illustrations below*.

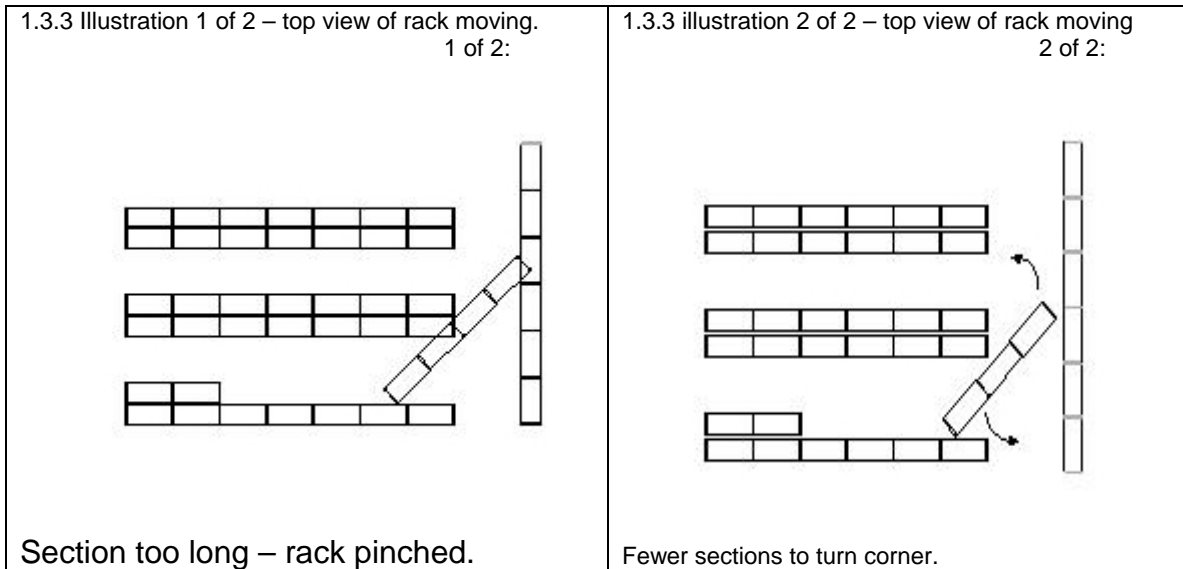

1.4. Equipment inspection – Prior to each use the PR Skate moving system should be inspected for damage and/or defect. *If any cracks, damage, and/or defects are found on a skate or lifting bracket, that equipment should be set aside and marked for non-use.*

All inspections must be made prior to the move of every run of pallet rack. Think Safety First.

2. System Set-Up

2.1. Staging equipment – We suggest staging all equipment prior to the start of raising the first upright or frame off the floor.

2.1.1. Skates – After you have determined how many uprights or frames that will be moving, place two skates near each upright or frame. Place one skate near the front post of the upright or frame and one near the back post of the upright or frame. This will reduce the time the rack will be raised off the floor and suspended by the lifting system. *See illustration below.*

Illustration 2.1.1

1 of 1:

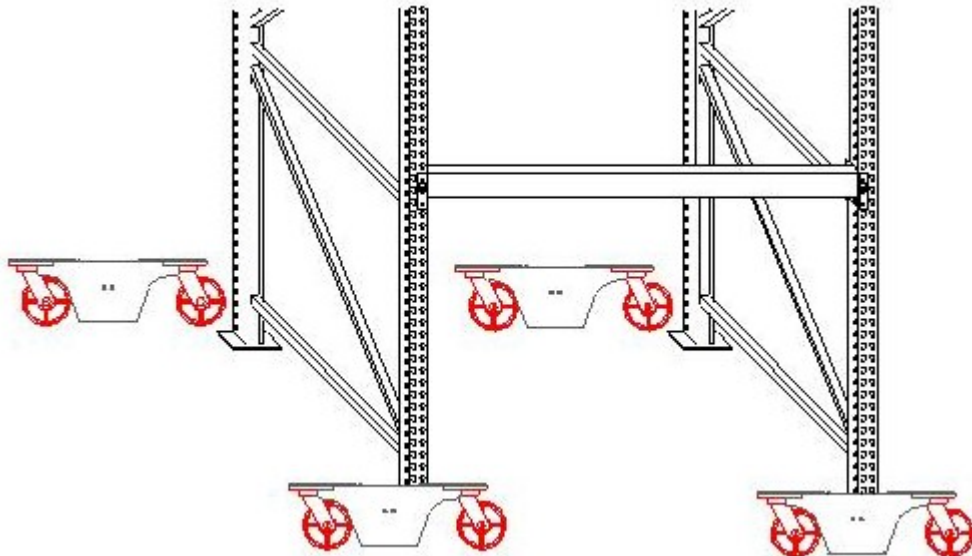

Staging skates

2.1.2. Lifting system – Place the lifting system (the pair of upright brackets, lifting bar, lifting bar bracket, and jack) near the first upright or frame to be raised off the floor. *The first upright or frame must be an end frame or upright (See illustration below).*

Illustration 2.1.2

1 of 1:

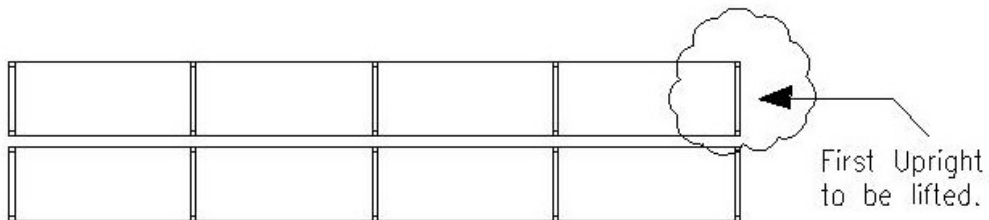

End frame or upright must be the first frame or upright to be lifted.

If using an air/hydraulic jack and are using air to raise the jack and frames or uprights, then the air source (compressor and hoses, or compressed air tank) should be stage for immediate use in the appropriate place.

2.2. Attaching lifting system

- 2.2.1.** Lifting system – Attach the Upright or Frame Brackets to the frame or upright at the end of the run (continuous bays of racking) using the 4 bolts supplied for each bracket. At least 3 of the 4 bolts must be used to attach the bracket to the frame or upright. The bolts must be inserted thru the entire column of the frame or upright. Only hand tighten the bolts until the lifting bar is inserted into the Upright or Frame Brackets. *Do not substitute a lower grade bolt than the ones supplied with the upright or frame brackets. See illustration(s) to the right.*

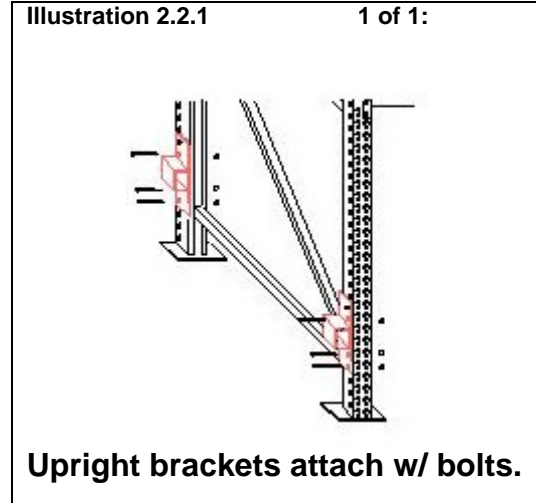

- 2.2.1.1.** Sliding Lifting Bracket – Once the Upright or Frame Brackets are secured to the frame or upright, slide the lifting bar into the Upright or Frame Brackets. Now tighten the bolts for the Upright or Frame brackets. Leave an equal overhang on both ends of the Upright or Frame Brackets. The Sliding Lifting Bracket slides along the Lifting Bar. The weight distribution on the frame or upright must be centered on the Sliding Lifting Bracket. Once you have estimated the center of weight distribution, tighten the setscrew to secure the Sliding Lifting Bracket to the lifting bar. This will help keep the load from sliding on the lifting bar. *See illustration(s) to the right.*

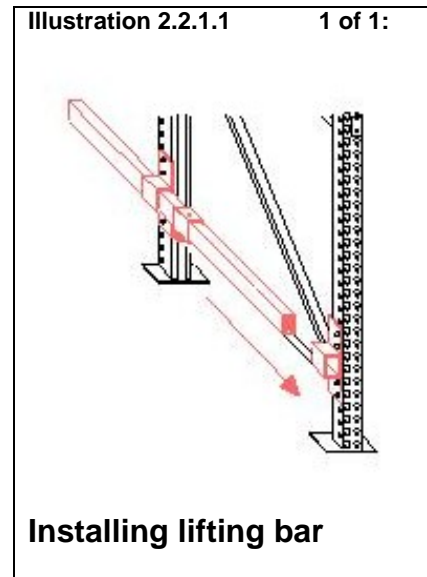

2.2.2. Anchors – The existing anchors securing the rack to the floor can at this time be removed. The procedure for this varies. Some will break the anchors; some will cut the anchors, while others will pound the anchors into the floor. Remember the floor to skate height is ½". The anchors need to be less than ½" out of the floor to attach the skates to the frames or uprights.

2.2.3. Support beams. **Support Beams must be installed** no more than 24" from ground prior to attaching skates. The support beams must be installed both front and back. The support beams will help keep the integrity of the columns of the uprights.

3. System In Action – *All inspections and staging of equipment must be done prior to the start of the use of the system.*

3.1. Lifting the Rack – Now that the lifting system is attached to the end upright or frame, you will now place the jack under the Sliding Lifting Bracket. The jack will rise up into the cup of the Sliding Lifting Bracket. Once the rack starts to rise off the floor, a spotter should evaluate the bay of rack for stability. If a problem develops during the lifting process, the rack should be lowered to the floor immediately and the safety inspections should be re-evaluated. **The maximum height the frame or upright should be raised off the ground is 1".** See illustration(s) to the right.

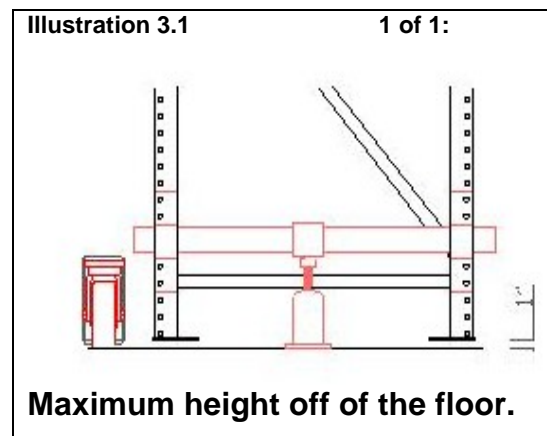

3.2. Attaching the Skates – Once the frame or upright is raised off the floor, the skates should be attached immediately. Roll the skates underneath the frame or uprights base plate and center the column of the upright or frame in the skate. Place the skate clamp on the back of the column of the frame or upright, insert bolts thru the slotted holes in the skates and thread into the Clamp Bracket. Tighten bolts to secure the skates to the frames or uprights. **Do not substitute a lower grade bolt**

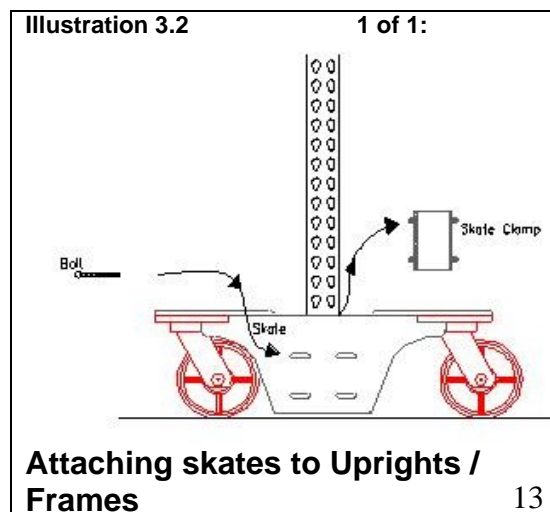

than the ones supplied with the Clamp Brackets. See illustration(s) to the right.

3.3. Lowering rack onto the skates – Once the skates are securely attached to both the front and back of the frame or upright, you should lower the frame or upright onto the skate. *Just as the frame or upright are touching the skate, stop lowering the frame or upright and orientate the wheels of the skate in the direction you will start to move the rack in.* Once the wheels are orientated proceed in lowering and applying the weight to the skates. See illustration(s) to the right.

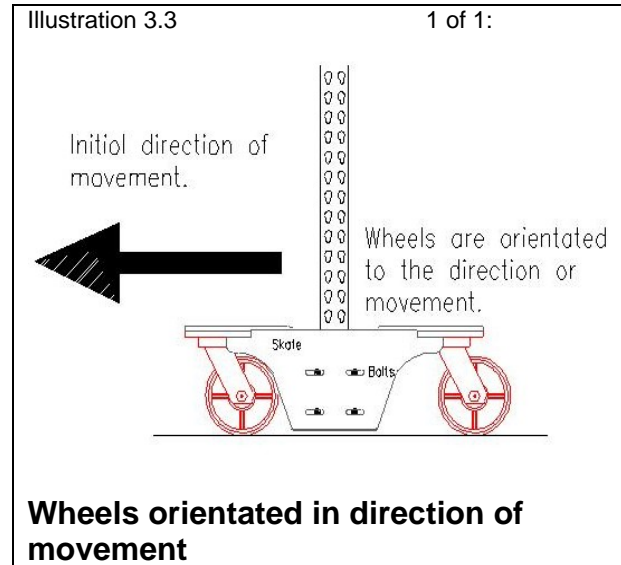

After all the weight is on the skates and not on the lifting system, proceed to detach the lifting system and move it to the next upright or frame. At this point you would repeat sections 2.2 thru 3.3 until all uprights or frames are attached to the skates and are lowered to the floor.

3.4. Moving rack to new location – In moving the rack to the new location, we recommend in pushing the rack with people not forklifts. With people pushing you have more control of stopping, starting, corners and unforeseen obstacles. The number of people needed will vary on many factors that would include but may not be limited to; weight of the entire mass and the length of the rack to be moved. When moving the rack, a slow, steady, and controlled pace should be maintained for safety.

3.5. Lifting rack for skate removal - Once the rack has been moved to point "B", you remove the skates from the rack and lower the rack to the floor. Hopefully you had already snapped your chalk lines where the new location is for your rack. Line the rack up with your chalk lines and raise up the end upright with the lifting system. The lifting system is used the same way for skate removal as it is for attaching the skates (See 2.2.1., 2.2.1.1., & 3.1.)

3.6. Skate removal – With the weight off the skates and on the lifting system, remove the bolts for the upright or frame to skate clamp. Once the clamps are removed from the upright or frames and skates, remove the skates by rolling them out and away from the racking.

3.7. Lowering the rack into place – Now that the skates are removed, lower the rack to the floor by turning the hydraulic release valve on the jack counter-clockwise. Turn the release valve slowly to prevent the rack from slamming onto the floor. The same process for must be done to remove and lower each frame or upright to the floor. See 3.5. & 3.6.

4. Post system & clean up

4.1. Rack anchoring – Once the entire run (continuous bays of racking) is lowered to the floor, the run of rack must be anchored or secured to the floor. In order to do this, refer to your local codes and/or engineering calculations for your racking. Your racking must be anchored to the floor for safety.

4.2. Clean up – Every effort should be made to clean the entire work area. This would include sweeping, vacuuming the anchor dust, gathering equipment and tools, pick up and dump garbage, and restock any displaced material or product.

4.3. Safety inspections – The final safety inspection would include; checking the anchors torque, inspect all beams for missing safety pins and/or bolts, inspect work areas for lose equipment or tools, check for product that may have become unstable during the move of the pallet rack, and check the PR Skate moving system for damage, defects, or cracks.

4.4. Packing the system for storage – The PR Skate moving system should be packed in its original crate for storage. Do not discard any packing material that your system originally came with. It should be used when packing the system for storage so that the contents of the system will remain stable with in the crate.

The P.R. Skate

Suggested tool / supply list.

- Electric or Cordless impact gun
- Roto-Hammer and accessories
- 5 lbs. Maul hammer
- Socket set
- Open end wrench set
- Dead Blow Hammer
- Grease gun
- Reciprocating saw
- 4" grinder
- Push broom

